

Diaphragms

The diaphragm is the most important component of the diaphragm valve.

Besides the valve body, the diaphragm is the only part which contacts the process medium.

The diaphragm separates the process medium from the actuator and the external atmosphere.

In addition, the diaphragm is the dynamic part which the flow rate of the process medium is controlled and stopped.

All aseptic diaphragms used by SED have been developed and tested over the years.

The SED diaphragms are subject to stringent testing in our own test stands at different operating conditions.

These tests are continuously performed in a saturated steam sterilization loop to determine estimated cycle life times.

The test results have an influence on the design, composition of materials, valve body design and complete valve assemblies.

All diaphragms are produced with an embedded stainless steel compressor stud for the engagement at the valve operating mechanism except for the diaphragm dimension MA8 which is connected with the valve activation by an elastomer button.

All diaphragm materials of the same size have the same engagement with the valve operating mechanism and may be interchanged in the valve without changing the diaphragm compressor and spindle.

The traceability of raw materials is available through the diaphragm code which defines the material and states the production lot and production date.

MA*	25	40	50	80
A	46	65	78	114
B	54	70	82	127

*Diaphragm size

SED Code	18	30	44
MA	8 - 100	8 - 50	25 - 100
Material	EPDM	PTFE/EPDM	PTFE/EPDM
Design	One-piece Molded open	One-piece Molded open	Two-piece Molded closed
Temperature range	(°C)	-40 to 150*	-20 to 150
	(°F)	-40 to 300*	-20 to 300
FDA			
3A			
USP Class VI Test section #87 & #88			

The listed temperatures may apply to clean steam sterilization protocols and may not apply to continuous steam service. Upon request, other diaphragms are available with other materials and for higher temperature up to 175°C/350°F.

MA 8

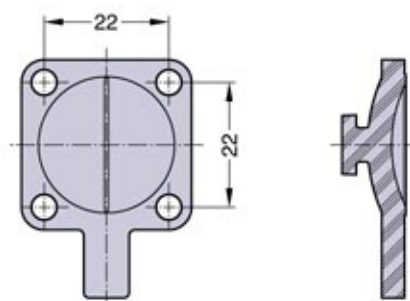

MA 10

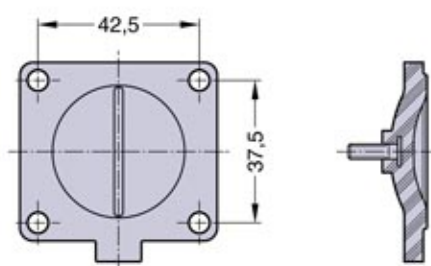

MA 25 - 80

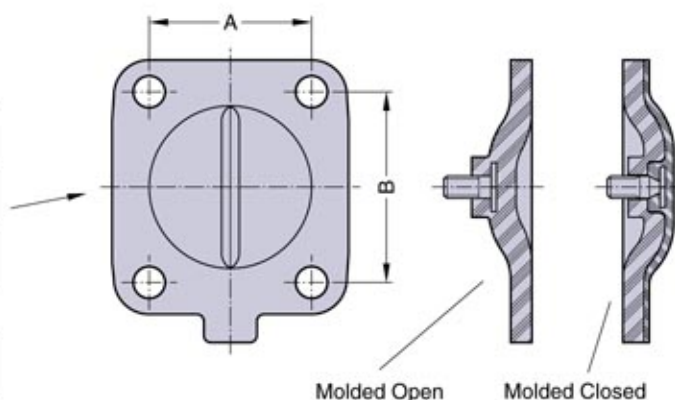

MA 100

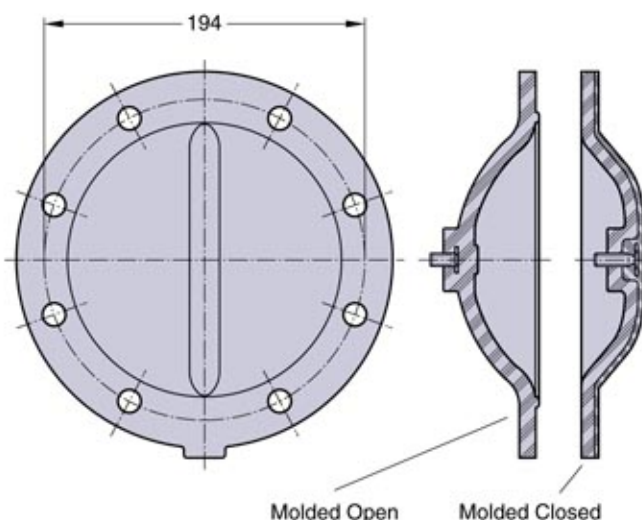

Diaphragms

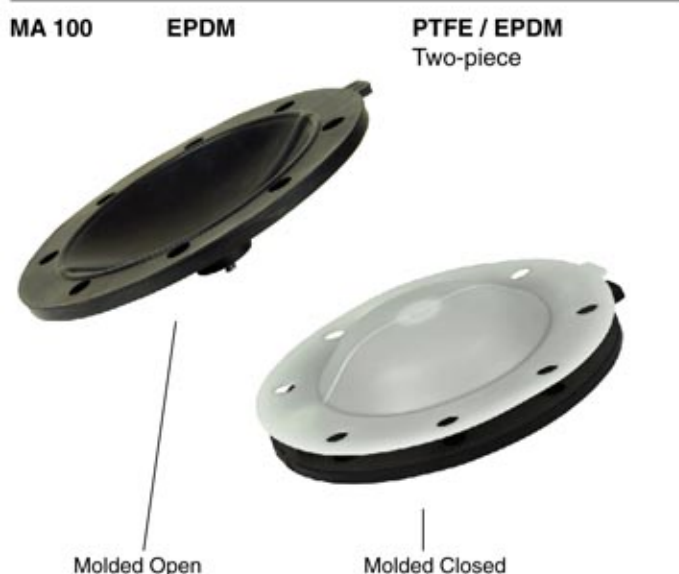
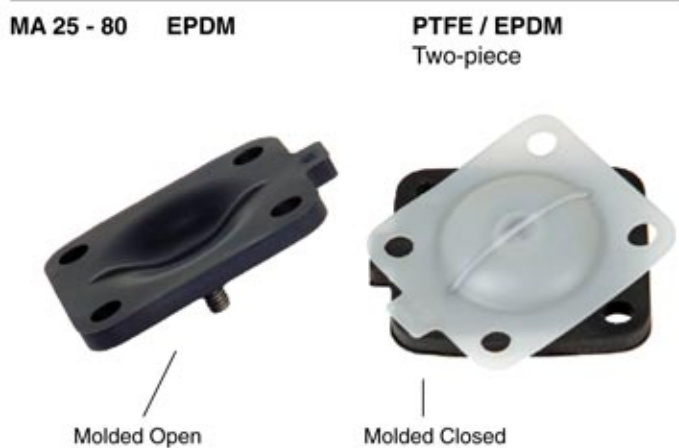
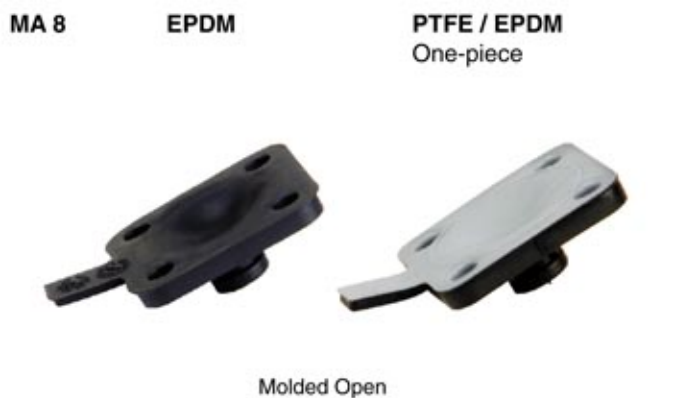

EPDM SED Code 18

Ethylene-propylene elastomer peroxide cured. The SED EPDM is a specifically developed compound reinforced with a vulcanized woven fabric inlay and is always manufactured in the molded open position. This diaphragm construction achieves higher stability for the diaphragm at elevated temperatures and pressures. In addition, the woven fabric inlay is vulcanized over the embedded compressor stud in order to strengthen the elastomer-metal connection. Thus, the EPDM diaphragm is ideal for vacuum applications.

The Code 18 Diaphragm

- Complies to FDA CFR # 21 Section 177.2600
 - Conforms to USP Class VI Test section #87 and #88
 - 3A Sanitary Class II
- (Certificate of Conformity available upon request)

PTFE (TFM) Diaphragm Code 30 and 44

These PTFE diaphragms have been designed and offer the highest degree of chemical resistance, increased stability, longer flex life, less porosity, reduced cold flow and superior performance through temperature fluctuations between hot and cold and steam sterilization cycles.

MA8 and MA10

The diaphragm dimensions MA8 and MA10 are designed as one-piece diaphragms: This means that the EPDM back is bonded with the PTFE.

The diaphragm is always manufactured in the molded open position. These one-piece diaphragms have less surface area and are subject to shorter linear strokes which explain the excellent performance that has proved itself over time.

MA8 diaphragm incorporates an elastomer button for assembly with the valve operating mechanism. The MA10 utilizes a threaded stud assembly with the valve operating mechanism. Both these features eliminate the potential for point loading at the center of the diaphragm.

MA25 to MA100

The diaphragm dimensions MA25 to MA100 are designed as two-piece diaphragms-consisting of a separate EPDM backing cushion and PTFE diaphragm. The diaphragm is always manufactured in the molded closed position. The advantage of this design for the MA25 to MA100 is that the diaphragm is in its molded shape while in the closed position of the valve. This reduces the force to close the valve and increases the life of the diaphragm.

In the two piece diaphragms the threaded stud connection is embedded in the PTFE of the diaphragm. To eliminate the potential of point loading at the center of the diaphragm, a floating suspension connection to the valve operating mechanism is utilized.

The Code 30 and 44 Diaphragm

- Complies to FDA CFR # 21 Section 177.1550
 - Conforms to USP Class VI Test section #87 and #88
 - 3A Sanitary Class I
- (Certificate of Conformity available upon request)